

Figure 1
Wall Mounted
SLX 130 Sensor

There are two primary methods of mounting the SLX 130 submersible level sensors: suspended by its signal cable and pipe mounting to the side of a vessel. Each SLX 130 ships with the material and instructions required for suspending the sensor from its signal cable. (Reference drawing 10003-0001 for cable mounting instructions.)

The SLX 130 has a 3/4" female NPT fitting for pipe mounting to a bracket that is secured to the wall. The customer must slip the transducer's cable through the mounting pipe (customer supplied), thread the pipe to the sensor housing, and firmly secure the pipe to the wall.

Use two SLX PBkt bracket kits to secure the pipe to the wall. For ease of installation and maintenance, the brackets may be mounted above the wet well's typical operating level.

Mount the channel(s) horizontally to the wall. After the channels are securely mounted, secure the sensor at its proper mounting elevation. The transducer must be mounted vertically, with its diaphragm at least 6 inches above the bottom of the vessel. Do not rest the sensor on the bottom during installation.

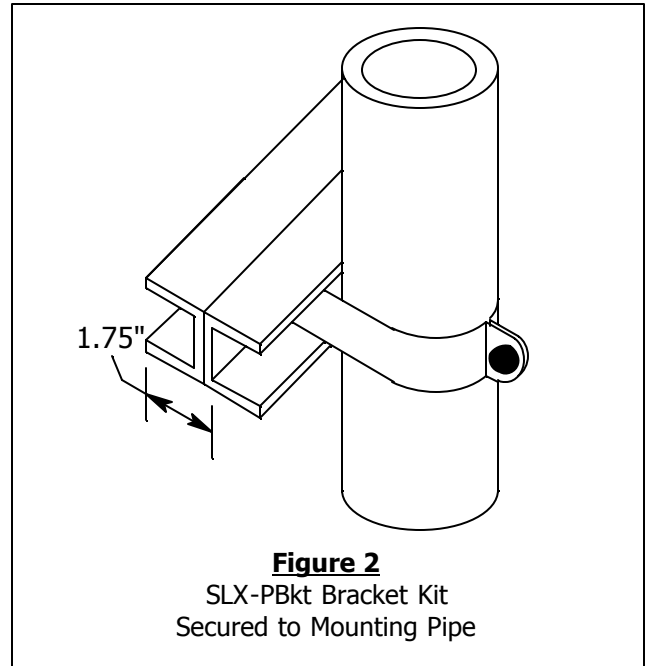

Figure 2
SLX-PBkt Bracket Kit
Secured to Mounting Pipe

- SLX-PBkt Pipe Bracket Kit (PN 30025-0002-01)** includes:
- 1 - Mounting Channel (Two channels, secured back-to-back)
 - 2 - Mounting Clamp halves for 3/4" pipe (identical halves)
 - 1 - Screw
 - 1 - Nut

All mounting hardware is 316 SS.

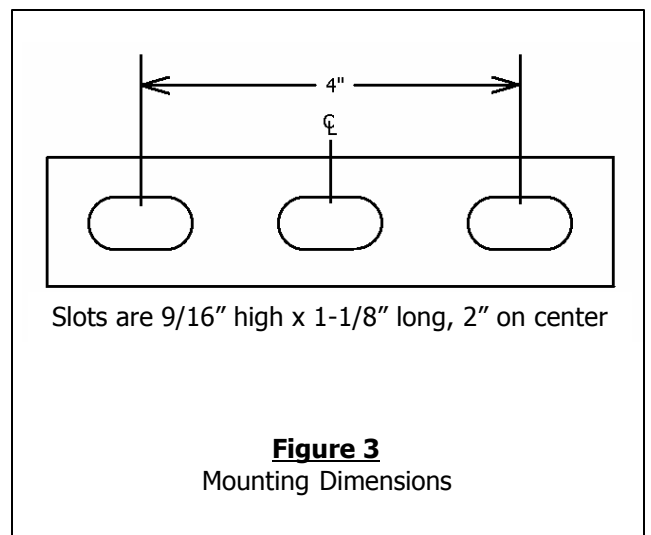

Figure 3
Mounting Dimensions