

Hydraulic Connections

Reference Figure 1.

The water main is tapped in the side and the pressure-sense line is trapped downward to inhibit the entrance of air or debris into the sense line. Tapping the side of the pipe decreases entrance of debris into the sensing line; the debris is assumed to be at the bottom of the pipe. Trapping the line downward prevents air from entering the sense line.

Provide a shutoff valve at the pressure tap location so the sensing line and equipment can be easily serviced. Provide a bleed valve close to the GPX 220 to allow all air to be purged from the sense line and for easy field calibration.

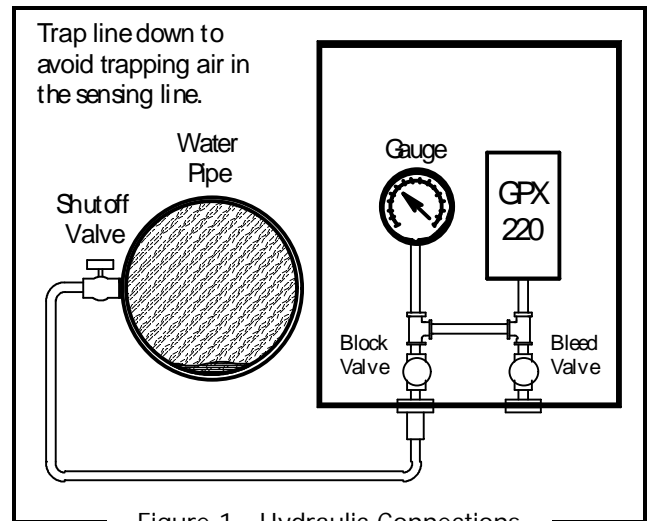

Figure 1 - Hydraulic Connections

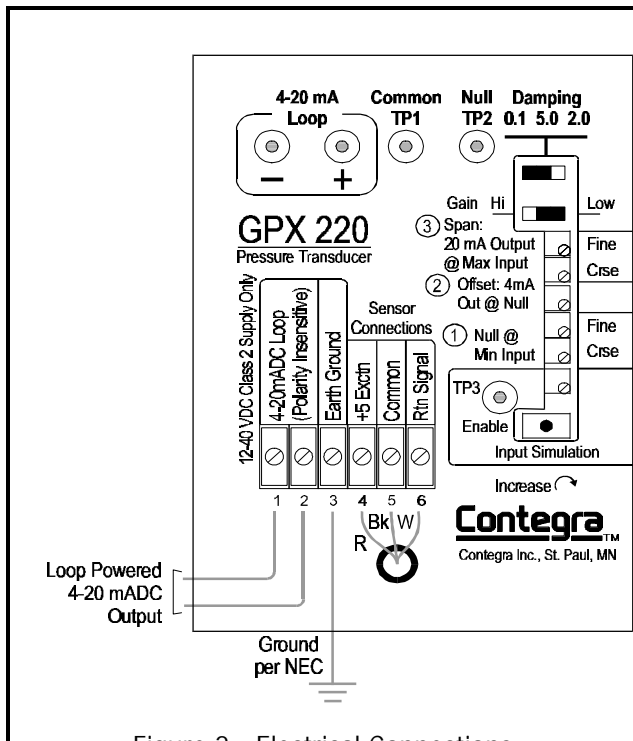

Figure 2 - Electrical Connections

Electrical Connections

Reference Figure 2.

1. Terminal 3 (EARTH GROUND) must be grounded per the National Electric Code (NEC). Failure to properly ground the GPX 220 voids the warranty.
2. The 4-20 mADC loop must be powered by a UL approved Class 2 power supply.
3. The GPX 220 (at terminals 1 & 2) requires a minimum of 12 VDC, the lift-off voltage, and accepts a maximum of 40 VDC. The power supply must be sized to accommodate the sum of the loop resistance and the in-circuit resistance of all connected controllers.

- The Min voltage = 12 VDC + (resistance X 0.02)
- The Max voltage = 40 VDC + (resistance X 0.02)
- The Max load = (supply voltage - 12) X 50

The maximum load includes loop resistance and the resistance of all connected equipment.

(Continued from page 1)

Calibration

(The transducer is factory calibrated per the purchase order. Therefore, field calibration is rarely required.)

Tools required:

- DVM – Digital Volt Meter¹
- Trim tool for potentiometer adjustment

Benchtop Calibration (w/Cal Stand)

1. Apply the “zero scale” pressure to the sensor (i.e. the pressure at which 4 mA is to be transmitted).
2. Measure the voltage from TP1 (common) to TP2 (Null).
3. Adjust the potentiometers labeled “**Null @ Min Input**” (course and fine) until zero volts is measured between TP1 and TP2.
4. Monitor the 4-20 mADC loop current by placing the DVM’s probes in the GPX 220’s 4-20 mADC test points found in the upper left corner.
5. Adjust the potentiometer labeled “**Offset: 4 mA Out @ Null**” until 4 mA is measured.
6. Apply full-scale pressure to the sensor.
7. Adjust the potentiometers labeled “**Span: 20 mA Output @ Max Input**” (course and fine) until 20 mA is measured. If a small excursion is being measured, the “gain” jumper may need to be moved to the “Hi” setting to achieve the required 20 mA output.
8. Finally, choose the desired Damping time constant². Three time constants are available: 0.1 (jumper @ left), 2.0 (jumper @ right) and 5.0 (jumper removed) seconds.

Field Calibration

1. Apply the ‘zero scale’ pressure to the sensor (i.e. the pressure at which 4 mA is to be transmitted). Close the block valve and bleed pressure from the pressure sense line until the pressure gauge indicates the ‘zero scale’ pressure.
2. Measure the voltage from TP1 (common) to TP2 (Null).
3. Adjust the potentiometers labeled ‘**Null @ Min Input**’ (course and fine) until zero volts is measured between TP1 and TP2.
4. Monitor the 4-20 mADC loop current by placing the DVM’s probes in the GPX 220’s 4-20 mADC test points found in the upper left corner.

5. Adjust the potentiometer labeled ‘**Offset: 4 mA Out @ Null**’ until 4 mA is measured.
6. Apply full-scale pressure to the sensor.
 - a) Open the shutoff valve.
 - b) Fill the tank to ‘full’.
7. Adjust the potentiometers labeled ‘**Span: 20 mA Output @ Max Input**’ (course and fine) until 20 mA is measured. If a small excursion is being measured, the “gain” jumper may need to be moved to the “Hi” setting to achieve the required 20 mA output.
8. Finally, choose the desired Damping time constant². Three time constants are available: 0.1 (jumper @ left), 2.0 (jumper @ right) and 5.0 (jumper removed) seconds.

‘Simulated’ Calibration

The ‘Input Simulation’ feature may be used to calibrate the GPX 220. If the GPX 220 is being applied at a standpipe you may pre-calibrate the unit before field installation and start-up. This feature is not recommended for elevated tanks or closed pumping systems where the 4-20 mA output represents a narrow span of the sensor’s full scale range - in these applications simulated calibration recommended for preliminary calibration prior to field calibration. Visit www.contegra.com for the GPX simulated calibration instructions.

Footnotes:

- 1) When using the GPX 220’s 4-20 mADC test points, best accuracy is achieved by using DVM’s with a burden voltage less than 5.0 mV/ mA (i.e 5 ohm sense resistance). If using a DVM with a higher sense resistance the installing technician should calibrate by intercepting the 4-20 mADC current loop.
- 2) The time constant is defined as the time it takes for the GPX 220 to reach an output response of 63.2% of the input value upon a change in pressure.