

FLOAT SWITCH

NON-MERCURY, 316 SS



MODEL FS 90

FEATURES

- 316 Stainless Steel float ball and hardware
- 5 1/2" diameter float for exceptional buoyancy
- Mercury free switch
 - Long-life mechanical rating
 - Form C contact rated 25 Watts at 120 VAC
 - Differential action
- Fixed level, cable or pipe suspension mounting



CONTEGRA's FS 90 is a rugged, reliable raw sewage or sludge wet well point-level sensing device. It is also applicable as a process sump or water reservoir sensor where its simplicity of operation, quality, and ruggedness provide years of reliable service.

Two simple mounting methods are available: cable or pipe. Cable suspension provides simplicity of installation and adjustment of the pump on/off and alarm setpoints as shown in the figure at the right. Alternatively, the floats can be mounted on a pipe as pictured above.

The switch has a 8" differential. The switch activates when the process level rises 4" above the fixed mounting position and deactivates when the level decreases to 4" below the fixed mounting position.

Contegra[®]

MODEL FS 90

Specifications

Float Construction: 316 Stainless Steel, 5 1/2" diameter, 20 gauge, with Laminex™ non-stick coating

Cable: 16 gauge, 4 conductor, SEOW. Rated "continuous service" for flexibility and longevity.

Switch: SPDT reed switch

Mechanical Life: 10 million operations

Connections:

White = Common
 Black = Normally Open (NO)
 Red = Normally Closed (NC)
 Green = Ground

Operating Levels:

"On" setpoint: 2-3" above the fixed mounting level (nominal)

"Off" setpoint: 2-3" below the fixed mounting level (nominal)

Buoyancy: 2# net

Contact Ratings: 150 VDC/VAC max.

1 Amp. max., 25 Watts max.,

Non-inductive

CONTEGRA and Laminex are trademarks of Contegra Inc. Specifications are subject to change without notice.

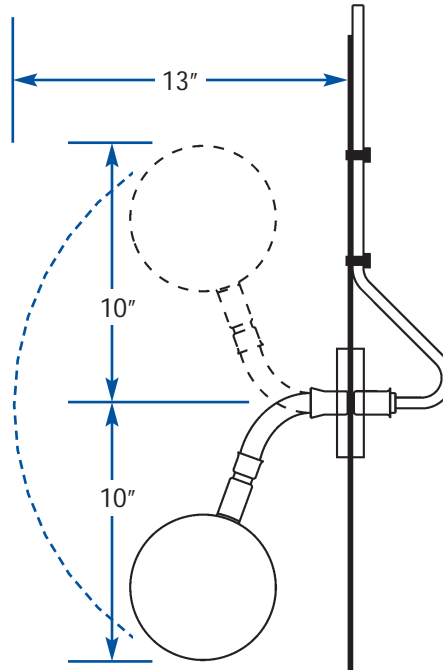

Engineering Specs

The level sensing device shall be a 5 1/2" diameter, 316 stainless steel float switch. The switch shall be mercury free.

The switch shall be SPDT, rated 25Watts at 120 VAC with a mechanical life of 10 million operations.

The float cable shall be rated "continuous service" for high flexibility.

The float switch(es) shall be cable/pipe mounted as shown on the plan drawings. All mounting hardware shall be 316 SS. All float fittings shall be flared and incorporate strain relief jacketing.

The Model FS 90 float switch shall be furnished in quantities, cable lengths, and with accessories as shown in the plan drawings.

The float switch shall be a CONTEGRA Model FS 90 and shall have a 3 year warranty.

Ordering Information (see example below)**

Model	Feet of cable	Mounting Hardware	Accessories
FS 90	XXX	X	FS-SC XX = Suspension cable kit with XX feet of cable
	20 ft. minimum	C = Cable mounting clamp	FS-Wgt15 = Weight for FS-SC
	10 ft. increments	P = Pipe mounting clamp	FS-PBkt = Pipe wall mounting bracket

A typical model number is **FS 90-30-C which includes a FS 90 float switch with 30 feet of cable and a suspension cable mounting clip. Accessories are specified as separate line items.

Represented by:

Contegra Inc.
 1286 Carriage Hills Drive
 Eagan, MN 55123

PHONE: 651-905-0900
 FAX: 651-454-4665
 INTERNET: www.contegra.com

