

FLOAT SWITCH

MERCURY, 316 SS



MODEL FS 96

FEATURES

- 316 Stainless Steel float ball and hardware
- 5 1/2" diameter float for exceptional buoyancy
- Form C mercury switch
- Fixed level, cable or pipe suspension mounting

Contegra's FS 96 is a rugged, reliable raw sewage or sludge wet well point-level sensing device. Its simplicity of operation, quality, and ruggedness provide years of reliable service.

The FS 96 comes standard with a SPDT mercury switch – a "first" for the high-buoyancy 316 SS float ball market! The Form C switch configuration simplifies stocking requirements and installation. There is no longer a need to stock both normally-open AND normally-closed float switches; the FS 96 float switch contains both.

Two simple mounting methods are available: cable (pictured at right) and pipe (pictured above). Where mercury usage must be minimized, Contegra offers the FS 90 mercury-free float switch.



Contegra

MODEL FS 96

Specifications

Float Construction: 316 Stainless Steel, 5 1/2" diameter, 20 gauge, with Laminex™ non-stick coating

Cable: 16 gauge, 4 conductor, SEOW. Rated "continuous service" for flexibility and longevity.

Switch: SPDT mercury switch, break before make, 10° differential. Encapsulated.

Contact Ratings:

120 VAC max.
1 Amp. max.

Connections:

White = Common
Black = Normally Open (NO)
Red = Normally Closed (NC)
Green = Ground

Operating Levels: 2.5" differential (nominal)

Buoyancy: 2# net

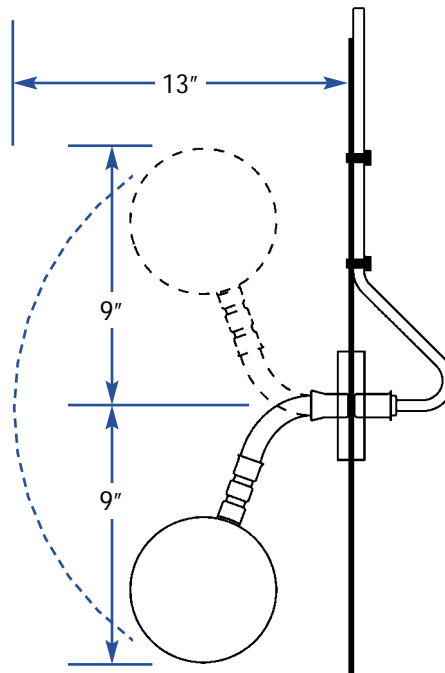

Engineering Specs

The level sensing device shall be a 5 1/2" diameter, 316 stainless steel float switch.

The float shall have a SPDT mercury switch, rated 10 Amps at 240 VAC with 10° differential action.

The float cable shall be rated "continuous service" for high flexibility.

The float switch(es) shall be cable/pipe mounted as shown on the plan drawings. All mounting hardware shall be 316 SS. All cable fittings shall be flared and incorporate strain relief jacketing.

The Model FS 96 float switch shall be furnished in quantities, cable lengths, and with accessories as shown in the plan drawings.

The float switch shall be a Contegra Model FS 96 and shall have a three year warranty.

Ordering Information (see example below)**

Model	Feet of cable	Mounting Hardware	Accessories
FS 96	XXX	X	FS-SC XX = Suspension cable kit with XX feet of cable
	20 ft. minimum	C = Cable mounting clamp	FS-Wgt = Weight for FS-SC
	10 ft. increments	P = Pipe mounting clamp	FS-PBkt = Pipe wall mounting bracket

Contegra and Laminex are trademarks of Contegra Inc. Specifications are subject to change without notice. Please visit www.contegra.com for current information.

****A typical model number is FS 96-30-C** which includes a FS 96 float switch with 30 feet of cable and a suspension cable mounting clip. Accessories are specified as separate line items.



Represented by:

Contegra Inc.
1286 Carriage Hills Drive
Eagan, MN 55123

PHONE: 651-905-0900
FAX: 651-454-4665
INTERNET: www.contegra.com