



intelligent design?

# CD-3RB

## User's Guide

Float Based  
Redundant Control  
(Pump Down)

### Overview

The CD-3RB redundant pump controller accepts from one to a maximum of four float control inputs and provides automatic pump-down control of three constant speed pumps.

#### Pump Off Input/Float

If a "Pump Off" float is connected, the CD-3RB deactivates pump control output when that float opens. The pumps are timed on (as described below) but they are turned off as a group when the Off float opens.

If the "Pump Off" float is NOT connected, the CD-3RB deactivates pump control output on a timed bases as demand decreases.

#### Lead Input/Float

If a single float is used at the "Lead Req'd" input (AKA "Run One Pump"), the CD-3RB starts only one pump when that input is activated.

When the float switch opens, the CD-3<sup>RD</sup> continues to operate that pump until the Lead Pump Off-Delay timer completes its timing cycle.

#### 1<sup>st</sup> Lag Input/Float

If a single float is used at the "1<sup>st</sup> Lag Req'd" input (AKA "Run 2 Pumps"), the CD-3RB sequentially starts two pumps when that input is activated. The Lead pump starts immediately. Assuming that the float switch remains closed, the 1<sup>st</sup> Lag pump starts after a brief time delay (1<sup>st</sup> Lag Enable).

When the float switch opens, the CD-3RB continues to operate the 1<sup>st</sup> Lag pump while its associated timer (1<sup>st</sup> Lag Off-Delay) completes its timing cycle. (Closing the float switch resets the timer.) Upon completion of the 1<sup>st</sup> Lag Off-Delay timer's cycle, one of the two pumps is removed from service. (The alternator advances and the pump that has been operating the longest is removed from service.)

The CD-3RB begins timing off the Lead pump when the 1<sup>st</sup> Lag Pump turns off. If the 1<sup>st</sup> Lag float remains open, the CD-3RB completes the Lead Pump Off-Delay timing and then deactivates the remaining pump output.

#### 2<sup>nd</sup> Lag Input/Float

If a single float is used at the "2<sup>nd</sup> Lag Req'd" input (AKA "Run 3 Pumps"), the CD-3RB sequentially starts three pumps when that input is activated. The Lead pump starts immediately. Assuming that the float switch remains closed, the 1<sup>st</sup> Lag pump starts after a brief time delay (1<sup>st</sup> Lag Enable). Again assuming that the input remains active the CD-3RB starts the third pump after a brief time delay (2<sup>nd</sup> Lag Enable).

When the float switch opens, the CD-3RB continues to operate the 2<sup>nd</sup> Lag pump while its associated timer (2<sup>nd</sup> Lag Off-Delay) completes its timing cycle. (Closing the float switch resets the timer.) Upon completion of the 2<sup>nd</sup> Lag Off-Delay timer's cycle, one of the three pumps is removed from service. (The alternator advances and the pump that has been operating the longest is removed from service.)

Assuming that the input remains inactive, the CD-3RB begins a timing cycle that removes the 1<sup>st</sup> Lag pump from operation. The CD-3RB continues to operate the 1<sup>st</sup> Lag pump while its associated timer (1<sup>st</sup> Lag Off-Delay) completes its timing cycle. (Closing the float switch resets the timer.) Upon completion of the 1<sup>st</sup> Lag Off-Delay timer's cycle, one of the remaining two pumps is removed from service. (Again, the alternator advances and the pump that has been operating the longest is removed from service.)

The CD-3RB begins timing off the Lead pump when the 1<sup>st</sup> Lag Pump turns off. If the 2<sup>nd</sup> Lag float remains open then the CD-3RB completes the Lead Pump Off-Delay timing and then deactivates the remaining pump output.

## Software Switches

---

The CD-3RB contains the following four software switches:

1. Configure the Alarm Output  
The CD-3RB's fourth output can be configured as either an alarm or monitor output. An Alarm output is normally inactive and activates on an alarm condition. Conversely, a Monitor output is normally active and deactivates on an alarm condition.
2. Bump The Alternator  
This momentary action software switch allows the operator to bump (i.e. advance) the alternator to the next pumping sequence.
3. Hold the Alternator  
This software switch allows the operator to lock the alternator into the present pumping sequence.
4. Alarm When Lead Pump is Req'd  
By default the controller activates its fourth output when the 1<sup>st</sup> Lag Pump is called into service. This software switch allows the operator to cause the fourth output activate when either the Lead or 1<sup>st</sup> Lag pump are called into service.

## Controller Inputs

---

### I8 – Acknowledge

Momentarily connecting +VDC to Input 8 (e.g. via a N.O. pushbutton) completes the acknowledgement circuit and deactivates Output #4. (Note: Output #4 automatically deactivates when the pumps are no longer required.)

### I7 – Pump 3 Running

Pump 3's counters and timers are activated when +VDC is connected to Input 7.

### I6 – Pump 2 Running

Pump 2's counters and timers are activated when +VDC is connected to Input 6.

### I5 – Pump 1 Running

Pump 1's counters and timers are activated when +VDC is connected to Input 5.

### I4 – 2<sup>nd</sup> Lag (i.e. 3 Pumps) Req'd

Activating the input (connecting +VDC to Input 4) causes the pumps to start in a timed sequence. The Lead pump starts immediately. The 1<sup>st</sup> Lag and 2<sup>nd</sup> Lag start only after a time delay and only if the input remains active.

### I3 – 1<sup>st</sup> Lag (i.e. 2 Pumps) Req'd & High Level Alarm

Activating the input (connecting +VDC to Input 3) causes the Lead and 1<sup>st</sup> Lag pumps to start in a timed sequence. The Lead pump starts immediately. The 1<sup>st</sup> Lag starts only after a time delay and only if the input remains active. Additionally, Output #4 activates to indicate an abnormal level condition.

### I2 – Lead Pump (i.e. 1 Pump) Req'd

Activating the input (connecting +VDC to Input 2) causes the Lead pump to start.

### I1 – Pump(s) Off

If an OFF float is NOT provided, the controller uses several internal Off-Delay timers to sequentially stop the pump(s).

However, a N.O. float may be used in order to provide a firm (i.e. not timed) Pump Off setpoint. A Normally-Open (i.e. closes on rising level) float switch is required. The controller senses the float closure (on rising level) and uses the OFF float to simultaneously deactivate all pump control outputs when the Pump Off input deactivates.

## Controller Outputs

---

### Q4 – Alarm Output (Selectable)

Q4 is an alarm output. A software switch (described in a subsequent section) allows the output to operate in an Alarm mode (close on alarm) or a Monitor mode (open on alarm).

The alarm output responds to the activation of the 2<sup>nd</sup> Lag Req'd / High Alarm input.

### Q3 – Pump #3 Control

Q3 is normally de-energized. The output energizes as required to control the operation of Pump 3.

### Q2 – Pump 2 Control

Q2 is normally de-energized. The output energizes as required to control the operation of Pump 2.

### Q1 – Pump 1 Control

Q1 is normally de-energized. The output energizes as required to control the operation of Pump 1.

## Integral Timers

---

Note: The CD-3RB goes through a five second start-up delay when power is applied. Thereafter, the pumps are sequenced on in an orderly fashion.

### Pump Add Timers

The CD-3RB contains two pump "ADD" timers (1<sup>st</sup> Lag Add and 2<sup>nd</sup> Lag Add).

1. The 1<sup>st</sup> Lag Add timer begins its timing cycle if additional pumping capacity is required and the Lead Pump is in service. The 1<sup>st</sup> Lag Add timer is adjustable from 0.00 to 99.99 seconds. Adjustment procedures are presented in a subsequent section of the manual
2. The 2<sup>nd</sup> Lag Add timer begins its timing cycle if additional pumping capacity is required and the 1<sup>st</sup> Lag Pump is in service.

## Off-Delay Timers

The CD-3RB contains three Off-Delay timers (2<sup>nd</sup> Lag Off-Delay, 1<sup>st</sup> Lag Off-delay and Lead Off-Delay). The three Off-Delay timers are disabled if an Off Float/Sensor is connected to Input #1.

1. The 2<sup>nd</sup> Lag Off-Delay timer begins its timing cycle when a reduction in pumping capacity is required (i.e. the 2<sup>nd</sup> Lag Req'd input is opened). When the 2<sup>nd</sup> Lag Off-Delay timer reaches the end of its timing cycle the 2<sup>nd</sup> Lag Pump is removed from service. The 2<sup>nd</sup> Lag Off-Delay timer is adjustable from 0.00 to 99.99 minutes. An internal (non-adjustable) timer limits the maximum Off-Delay time to 10:00 minutes. Adjustment procedures are presented in a subsequent section of the manual
2. The 1<sup>st</sup> Lag Off-Delay timer begins its timing cycle when the 2<sup>nd</sup> Lag Pump is inactive and a reduction in pumping capacity is required (i.e. the 2<sup>nd</sup> Lag Req'd and the 1<sup>st</sup> Lag Req'd inputs are open). When the 1<sup>st</sup> Lag Off-Delay timer reaches the end of its timing cycle the 1st Lag Pump is removed from service. As described above, the 1<sup>st</sup> Lag Off-Delay timer is adjustable from 0.00 to 99.99 minutes. Additionally, an internal (non-adjustable) timer limits the maximum Off-Delay time to 10:00 minutes.
3. The Lead Pump Off-Delay timer begins its timing cycle when the 1<sup>st</sup> Lag Pump is inactive and a reduction in pumping capacity is required (i.e. the 2<sup>nd</sup> Lag Req'd, 1<sup>st</sup> Lag Req'd and Lead Req'd inputs are open). When the Lead Pump Off-Delay timer reaches the end of its timing cycle the Lead Pump is removed from service. As described above, the Lead Off-Delay timer is adjustable from 0.00 to 99.99 minutes. Additionally, an internal (non-adjustable) timer limits the maximum Off-Delay time to 10:00 minutes.

A fourth internal (non-adjustable) timer limits the total accumulated Off Delay time to a maximum of 10 minutes.

## Display Screens

The CD-3RB contains a total of 10 display screens. Six of the displays are permanently enabled. These six displays – the Status Displays – show timer adjustments (i.e. Lag Add and Pump Off timing) and pump running time (i.e. Pumps 1 & 2 RTMs, etc.) The other four displays – Dynamic Displays – appear and are removed as the controller steps through its control sequence.

### Status Displays (Always Active)

<p><b>Initialization display</b> (Status 1) ↓ The display shows the controller's function (Redundant Controller) its model (CD-3RB) and reveals that no pumps are presently required. The fourth line indicates that more information is available by pressing the down pushbutton.</p>	<pre>RdndntContrl Model CD-3RB NoPumpsReq'd More Info ▼</pre>	<p>There are no user changeable setpoints on this display.</p>
<p><b>Adjust Pump Add Timer</b> (Status 2) ↓ This display allows the operator to view and change the 1<sup>st</sup> Lag and 2<sup>nd</sup> Lag "Add Delay" setpoints. 2Lag represents the present <b>2<sup>nd</sup> Lag Pump Add</b> setpoint (30:00sc = 30 seconds). The maximum timing value is 99 seconds.</p>	<pre>Adj PmpAddTmr 2Lag 30.00sc 1Lag 30:00sc See Label ▶</pre>	<p>Changing a setpoint is easy. See page 4 for instructions.</p> <p>Ensure that the timing range remains set to seconds.</p>
<p><b>Adjust Off Delay Timer</b> (Status 3) ↓ This display allows the operator to view and change the Off-Delay timers' setpoints. <b>2Lag</b> represents the present 2<sup>nd</sup> Lag Pump's Off Delay setpoint (00:30 mn = 30 Sec). <b>1Lag</b> represents the present 1<sup>st</sup> Lag Off Pump's Delay setpoint. <b>Lead</b> represents the present Lead pump Off Delay setpoint. The maximum value is 10:00 minutes.</p>	<pre>Adj OffDlyTmr 2Lag 00:30mn 1Lag 00:30mn Lead 00:30mn</pre>	<p>Changing a setpoint is easy. See page 4 for instructions.</p> <p>Ensure that the timing range remains set to minutes.</p>
<p><b>Pump 3 Timers</b> (Status 4) ↓ Pump 3's timers and counters are enabled by Input #7. Line 2 shows the run time (seconds) of the current pumping cycle. Line 3 shows an RTM that accumulates 1/10ths of hours (i.e. 453 = 45.3 hours). Line 4 shows the number of pump starts.</p>	<pre>Pmp3RTM&amp;Cntr Secnds 45 0.1Hrs 325 Starts 57</pre>	<p>There are no user changeable setpoints on this display. The RTM rolls-over at 999999.</p>
<p><b>Pump 2 Timers</b> (Status 4) ↓ Pump 2's timers and counters are enabled by Input #6. Please refer to the Pump 3 information (immediately above) for a line-by-line description.</p>	<pre>Pmp2RTM&amp;Cntr Secnds 45 0.1Hrs 325 Starts 57</pre>	<p>There are no user changeable setpoints on this display. The RTM rolls-over at 999999.</p>
<p><b>Pump 1 Timers</b> (Status 5) ↓ Pump 1's timers and counters are enabled by Input #5. Please refer to the Pump 3 information (above) for a line-by-line description.</p>	<pre>Pmp1RTM&amp;Cntr Secnds 15 0.1Hrs 342 Starts 56</pre>	<p>There are no user changeable setpoints on this display. The RTM rolls-over at 999999.</p>
<p><b>Tech Assist Displays</b> (Status 6...) ↓ There are a total of five Tech Assist Displays. The controller remembers the last Tech Assist Display to be viewed and returns to that display. Tech Assist Displays consist of the clock display (shown) an "Input" display, an "Output", a "Memory Marker" and a Soft Key (ESC Keys) display. Press  or  to view other Tech Assist displays. Press  to return to the Status Displays.</p>	<pre>Tu 08:50 2001-09-11</pre>	<p>There are no user changeable setpoints on the Tech Assist Displays.</p>

### Changing a Parameter

1. A setpoint value (described above) is changed as follows: Move to the desired setpoint (i.e. move to Status 2 or Status 3).
2. Press and hold the ESC pushbutton for approximately 3 seconds. A cursor appears in the second line from the top and at the left-most position [i.e. under the letter '2' in the cryptic label 2Lag (i.e. 2<sup>nd</sup> Lag)]
3. Press OK. The cursor moves to the setpoint's left-most digit.
4. Use the Right (or Left) arrow to move the cursor to the particular digit that is to be changed.
5. Use the Up and Down arrows to change the timing value. CAUTION: **DO NOT** change the timing range (i.e. do not change from sec => min => Hrs).
6. Press OK to accept the newly programmed value or press ESC to return the previous value.

## Dynamic Displays (Appear as Required)

### Lead Required – Lag Enable

(Dynamic 1) ↴

This screen appears upon the activation of any of the three "pump required" inputs. The Lag Enable Timers enforce a time delay between the starting of multiple pumps. Activating the "Lead Pump Required" inputs starts the 1Lag timer. Activating the "1<sup>st</sup> Lag Required" input starts the 2Lag timer.

```
LeadPmpReq' d
LagEnbl Tmrs ▼
2Lag 00:00sc
1Lag 00:00sc
```

Press 

There are no user changeable points on this display. The maximum delay is 99.99 seconds.

2Lag = 2<sup>nd</sup> Lag Pump On-Delay

1 Lag = 1<sup>st</sup> Lag Pump On-Delay

The CD-3RB can be used as a triplex-pump redundant controller. When used in such a manner, simply connect a single N.O. float switch to the High Alarm input. The CD-3RB immediately starts the Lead pump when the high alarm input closes. If the input remains active, the CD-3RB starts the 1<sup>st</sup> Lag Pump following the completion of the 1Lag delay (shown here). If the input continues to remain active, the controller starts the 2<sup>nd</sup> Lag Pump following the completion of the 2Lag delay.

### Pumps Timing Off

(Dynamic 2) ↴

This screen appears when the Off Float is not connected. In such cases the controller uses three programmable Off-Delay timers deactivate the pump control outputs. The screen appears when an active input changes state (i.e. deactivates). The 2<sup>nd</sup> line shows the 2<sup>nd</sup> Lag pump's off-delay value. The 3<sup>rd</sup> line shows the 1<sup>st</sup> Lag pump's off-delay value. The 4<sup>th</sup> line shows the Lead pump's off-delay value.

```
PmpsTi mngOff
2Lag 00:00mn
1Lag 00:00mn
Lead 00:00mn
```

Press 

There are no user changeable points on this display.

Move to the Status Displays (described previously) to view and change the respective timer's value.

As previously described, the timers are enabled when a reduction in pumping capacity is required and the "next higher" pump is no longer in service.

### Pump(s) On & ... Waiting

(Dynamic 3) ↴

This screen appears when a Pump Off input (i.e. float) is used. The CD-3RB started pumps based upon the activation of one of the Pump Required Inputs. However, those inputs are no longer active. At this point the controller is waiting for the Pump Off input to deactivate.

```
Pump(s) On!
Waiting for
PumpOffInput
to open.
```

Press 

There are no user changeable points on this display.

**Abnormal (High) Level Alarm** *(Dynamic 4)* ↓  
 Appears when the 1<sup>st</sup> Lag pump is required or (if enabled) when the Lead Pump is required. The display closes when the alarm acknowledge input is activated or on cessation of all pumping activity.

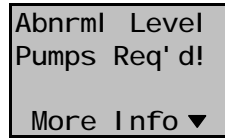

There are no user changeable points on this display.

Press

### Configuring User Configurable Parameters

The CD-3RB contains four user-configurable parameters. The parameters are:

1. Output #4 – Alarm or Monitor
2. Hold the Alternator Position
3. Advance the Alternator
4. Abnormal Level at Lead Pump Req'd

#### Output #4 - Alarm or Monitor

When Output #4 is used set in the alarm mode the output is activated by closure of the 2<sup>nd</sup> Lag/High Alarm input. The alarm can be silenced/ acknowledged by completing the ACK circuit (e.g. a NO pushbutton [by others] completes the circuit between +VDC and Input 8.)

Follow these steps to change the desired parameter:

1. Press the down arrow to move down to any one of the five Tech Assist Displays – described previously.
2. From one of the TechAssist displays, press and hold the ESC pushbutton until the following display appears =>

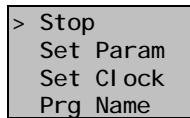

This menu is the entry point for the following options:

- ? Stopping the program (see the Cautionary Note on Page 8).
- ? Setting a parameter (Set Param),
- ? Setting the clock (Set Clock)
- ? Viewing the program name (Prg Name).

3. Press the Down pushbutton to and move the cursor down to **>Set Param.**

4. Press OK pushbutton and view the **Monitor?** display as shown =>

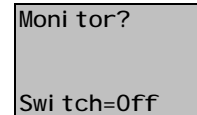

5. The top line indicates that the screen is used to change Output 4's function to the Monitor position.

When the Switch is Off then output #4 is set to the Alarm mode (i.e. activates on high level).

When the switch is On then output #4 is set to the Monitor mode (deactivate on high alarm).

6. To change the switch to the 'On' position simply press OK. The cursor responds by moving beneath the 'S' in the word 'Switch'
7. Press either the UP or DOWN arrow to toggle the switch to the ON position.
8. Press OK to accept the changed value or press ESC (before pressing OK) and thus preserve the present value.
9. Press ESC to return to the previous display =>
10. Press ESC to return to one of the Tech Assist displays.
11. Press the Up arrow to move through the status displays.

### Alternator Bump

This switch allows the alternator's sequence to be bumped (i.e. advanced) to the next sequence. The alternator operates in a 1-2-3, 2-3-1, 3-1-2 sequence. Bumping (i.e. Advancing) the alternator changes the present sequence to the successive sequence.

Follow these steps to bump (i.e. advance) the alternator's sequence:

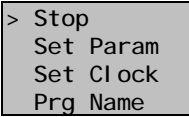
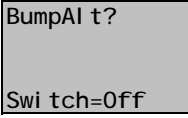
1. Press the down arrow to move down to any one of the five Tech Assist Displays – described previously.
2. From one of the TechAssist displays, press and hold the ESC pushbutton until the following display appears =>  

3. Press the Down pushbutton to and move the cursor down to **>Set Param.**
4. Press the OK pushbutton and view the **Monitor?** display as previously described.
5. Press the DOWN pushbutton and view the **BumpAlt?** display as shown =>  

6. The top line indicates that the screen is used to bump (i.e. advance) the alternator.
7. To temporarily change the switch to the 'On' position simply press OK. The cursor responds by moving beneath the 'S' in the word 'Switch'
8. Press either the UP or DOWN arrow to toggle the switch to the ON position.
9. Press OK to accept the changed value or press ESC (before pressing OK) and thus preserve the present value.
10. If the operator moves the switch to the **ON** position the CD-3RB provides a momentary switch closure. The CD-3RB's scan cycle may be fast enough so that the operator may have some difficulty seeing the switch transfer to the ON state. The CD-3RB keeps the switch in the ON state for a single scan cycle. Thereafter the CD-3RB immediately returns the switch position to OFF. Although the operator may not be able to observe the momentary switch action the operator can observe the outcome. The alternator has advanced its sequence to the subsequent position. [The alternator can only be bumped when the "Alternator HOLD" (described below) is in the OFF position.]

11. Press ESC to return to the previous display =>
12. Press ESC to return to one of the Tech Assist displays.
13. Press the Up arrow to move through the status displays.

### Alternator Hold

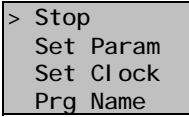
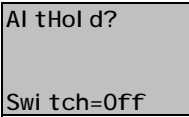
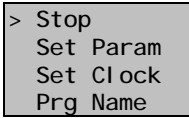
This switch allows the alternator's sequence to be held at the present sequence.

Follow these steps to HOLD the alternator's present sequence:

1. Press the down arrow to move down to any one of the five Tech Assist Displays – described previously.
2. From one of the TechAssist displays, press and hold the ESC pushbutton until the following display appears =>  

3. Press the Down pushbutton to and move the cursor down to **>Set Param.**
4. Press OK pushbutton and view the **Monitor?** display as previously described.
5. Press the DOWN pushbutton and view the **BumpAlt?** display as previously described.
6. Press the DOWN pushbutton and view the **AltHold?** Display =>  

7. The top line indicates that the screen is used to hold the alternator in its present sequence.
8. To change the switch to the 'On' position simply press OK. The cursor responds by moving beneath the 'S' in the word 'Switch'
9. Press either the UP or DOWN arrow to toggle the switch to the ON position.
10. Press OK to accept the changed value or press ESC (before pressing OK) and thus preserve the present value.
11. Press ESC to return to the previous display =>  

12. Press ESC to return to one of the Tech Assist displays.
13. Press the Up arrow to move through the Status displays.

### Alarm @ Lead Pump?

This switch allows the operator to activate the 4<sup>th</sup> output when the Lead Pump is called into service.

Follow these steps to "Alarm @ Lead" (i.e. Alarm when the Lead Pump is activated).

1. Press the down arrow to move down to any one of the five Tech Assist Displays – described previously.
14. From one of the TechAssist displays, press and hold the ESC pushbutton until the following display appears =>  

```
> Stop
Set Param
Set Clock
Prg Name
```
15. Press the Down pushbutton to and move the cursor down to **>Set Param**.
16. Press OK pushbutton and view the **Monitor?** display as previously described.
17. Press the DOWN pushbutton and view the **BumpAlt?** display as previously described.
18. Press the DOWN pushbutton and view the **AltHold?** Display as previously described.
19. Press the DOWN pushbutton and view the **Alrm@Ld?** Display =>  

```
Al rm@Ld?
Swi tch=0ff
```
20. The top line indicates that the screen is used to Alarm when the Lead Pump is called into service.
21. To change the switch to the 'On' position simply press OK. The cursor responds by moving beneath the 'S' in the word 'Switch'
22. Press either the UP or DOWN arrow to toggle the switch to the ON position.
23. Press OK to accept the changed value or press ESC (before pressing OK) and thus preserve the present value.
24. Press ESC to return to the previous display =>  

```
> Stop
Set Param
Set Clock
Prg Name
```
25. Press ESC to return to one of the Tech Assist displays.
26. Press the Up arrow to move through the Status displays.

### Caution

Do not change the timing range of the two internal timers.

The **Lag Off** timer is factory set to respond in **minutes** with a maximum off delay of 10 minutes. If the display does not appear as shown below, the timing range has been changed. It must be reset to 'mn' (minutes).

```
LeadPmpReq' d
LagEnbl Tmrs ▼
2Lag 00: 00sc
1Lag 00: 00sc
```

The **Pump Add** timer is factory set to respond in **seconds** with a maximum on delay of 99 seconds. If the display does not appear as shown below, the timing range has been changed. It must be reset to 'mn' (minutes).

```
PmpsTi mngOff
2Lag 00: 00mn
1Lag 00: 00mn
Lead 00: 00mn
```

A label has been applied to the right side of the controller. It reminds the operator of the adjustment procedure. Changing the timing range causes a noticeable change on the setpoint display.

The Lag Add and Pump Off adjustment displays show the respective timing ranges. The Lag Add timing range should show 'sc' which denotes 'Seconds'. The Pump Off timing range should show 'mn' which denotes minutes.

Examine the two displays. If either display is not as described, they're respective timing ranges must be restored to the proper value.

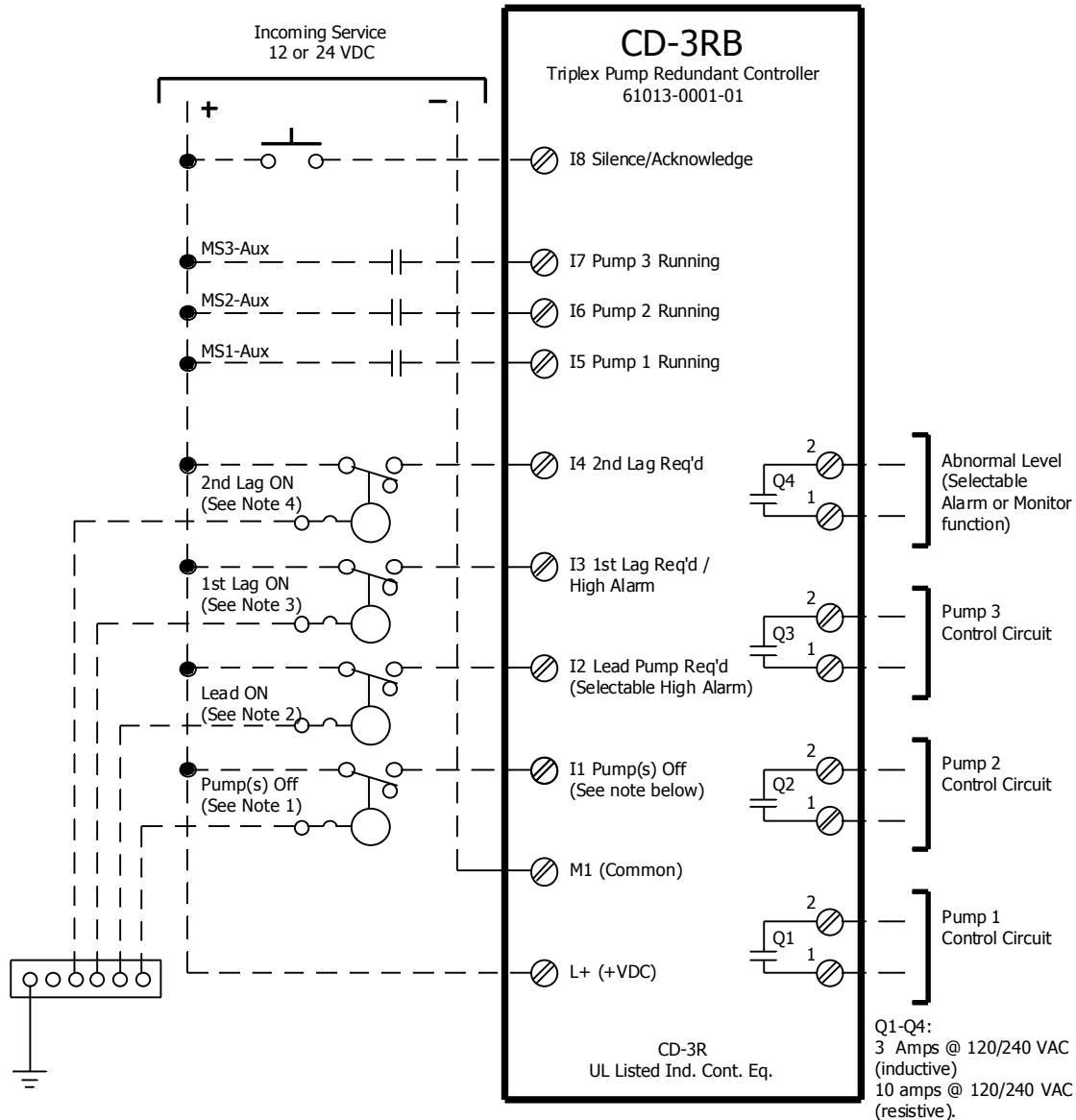

**Notes:**

- 1) If the 'Off' input is unused, then the pump(s) are sequentially timed off.
- 2) Using a single float at the Lead Pump Req'd input starts the Lead Pump. If an Off float is NOT provided the Lead Pump is timed off when the Lead Req'd input is removed.
- 3) Using a float at the 1st Lag Req'd input sequentially starts the Lead and 1st Lag Pumps. If an Off float is NOT provided the 1st Lag Pump is timed off when the 1st Lag Req'd input is removed.

- 4) Using a float at the 2nd Lag Req'd input sequentially starts the Lead, 1st Lag Pump and 2nd Lag pumps. If an Off float is NOT provided the 2nd Lag Pump is timed off when the 2nd Lag Req'd input is removed.